



01/2008:20908

2.9.8. RESISTANCE TO CRUSHING OF TABLETS

This test is intended to determine, under defined conditions, the resistance to crushing of tablets, measured by the force needed to disrupt them by crushing.

APPARATUS

The apparatus consists of 2 jaws facing each other, one of which moves towards the other. The flat surfaces of the jaws are perpendicular to the direction of movement. The crushing surfaces of the jaws are flat and larger than the zone of contact with the tablet. The apparatus is calibrated using a system with a precision of 1 newton.

OPERATING PROCEDURE

Place the tablet between the jaws, taking into account, where applicable, the shape, the break-mark and the inscription; for each measurement orient the tablet in the same way with respect to the direction of application of the force. Carry out the measurement on 10 tablets, taking care that all fragments of tablets have been removed before each determination.

This procedure does not apply when fully automated equipment is used.

EXPRESSION OF RESULTS

Express the results as the mean, minimum and maximum values of the forces measured, all expressed in newtons.

Indicate the type of apparatus and, where applicable, the orientation of the tablets.



07/2008:20909

2.9.9. MEASUREMENT OF CONSISTENCY BY PENETROMETRY

This test is intended to measure, under determined and validated conditions, the penetration of an object into the product to be examined in a container with a specified shape and size.

APPARATUS

The apparatus consists of a penetrometer made up of a stand and a penetrating object. A suitable apparatus is shown in Figure 2.9.9.-1.

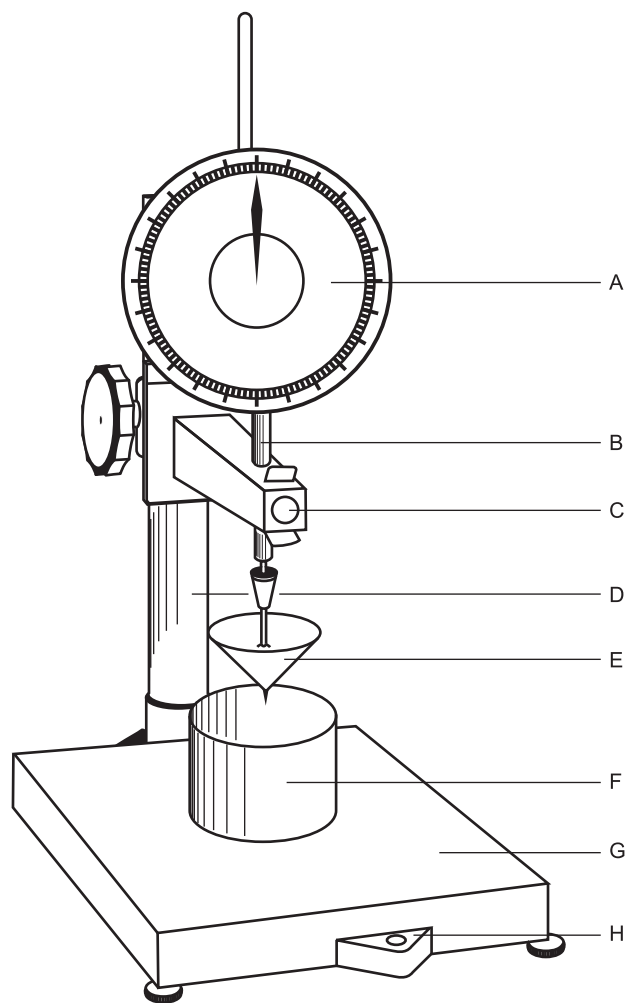

Figure 2.9.9.-1. – Penetrometer

- A. Scale showing the depth of penetration, graduated in tenths of millimetres.
- B. Vertical shaft to maintain and guide the penetrating object.
- C. Device to retain and to release the penetrating object automatically and for a constant time.
- D. Device to ensure that the penetrating object is vertical and that the base is horizontal.
- E. Penetrating object (see Figures 2.9.9.-2 and 3).
- F. Container.
- G. Horizontal base.
- H. Control for the horizontal base.

The stand is made up of:

- a vertical shaft to maintain and guide the penetrating object;
- a horizontal base;
- a device to ensure that the penetrating object is vertical;
- a device to check that the base is horizontal;
- a device to retain and release the penetrating object;
- a scale showing the depth of penetration, graduated in tenths of a millimetre.

The penetrating object, made of a suitable material, has a smooth surface, and is characterised by its shape, size and mass (*m*).

Suitable penetrating objects are shown in Figures 2.9.9.-2 and 2.9.9.-3.

PROCEDURE

Prepare the test samples according to one of the following procedures.