

ESTIMATE OF THE AMORPHOUS AND CRYSTALLINE FRACTIONS

In a mixture of crystalline and amorphous phases, the crystalline and amorphous fractions can be estimated in several ways. The choice of the method used depends on the nature of the sample:

- if the sample consists of crystalline fractions and an amorphous fraction of different chemical compositions, the amounts of each of the individual crystalline phases may be estimated using appropriate standard substances as described above; the amorphous fraction is then deduced indirectly by subtraction;
- if the sample consists of one amorphous and one crystalline fraction, either as a 1-phase or a 2-phase mixture, with the same elemental composition, the amount of the crystalline phase ('the degree of crystallinity') can be estimated by measuring 3 areas of the diffractogram:

- A* = sum of the area of all the peaks arising from diffraction of the crystalline fraction of the sample;
- B* = area under the curve in the diffractogram generated by the sample (excluding area *A*);
- C* = area of the background signal (due to scattering from air, fluorescence, equipment, etc).

When these areas have been measured, the degree of crystallinity can be roughly estimated using the following formula:

$$\% \text{ crystallinity} = 100A / (A + B - C)$$

It is noteworthy that this method does not yield absolute degree-of-crystallinity values and hence is generally used for comparative purposes only.

More sophisticated methods are also available, such as the Ruland method.

SINGLE CRYSTAL STRUCTURE

In general, the determination of crystal structures is performed from X-ray diffraction data obtained using single crystals. However, crystal structure analysis of organic crystals is a challenging task, since the lattice parameters are comparatively large, the symmetry is low and the scattering properties are normally very low.

For any given crystalline form of a substance, knowledge of the crystal structure allows the calculation of the corresponding XRPD pattern, thereby providing a 'preferred-orientation-free' reference XRPD pattern, which may be used for phase identification.



04/2019:20934

2.9.34. BULK DENSITY AND TAPPED DENSITY OF POWDERS⁽²⁰⁾

Bulk density

The bulk density of a powder is the ratio of the mass of an untapped powder sample to its volume, including the contribution of the interparticulate void volume. Hence, the

bulk density depends on both the density of powder particles and the spatial arrangement of particles in the powder bed. The bulk density is expressed in grams per millilitre despite the International Unit being kilogram per cubic metre (1 g/mL = 1000 kg/m³), because the measurements are made using cylinders. It may also be expressed in grams per cubic centimetre.

The bulking properties of a powder are dependent upon the preparation, treatment and storage of the sample, i.e. how it has been handled. The particles can be packed to have a range of bulk densities and, moreover, the slightest disturbance of the powder bed may result in a changed bulk density. Thus, the bulk density of a powder is often very difficult to measure with good reproducibility and, in reporting the results, it is essential to specify how the determination was made.

The bulk density of a powder is determined either by measuring the volume of a known mass of powder sample, which may have been passed through a sieve, in a graduated cylinder (Method 1), or by measuring the mass of a known volume of powder that has been passed through a volumeter into a cup (Method 2) or has been introduced into a measuring vessel (Method 3).

Methods 1 and 3 are favoured.

METHOD 1: MEASUREMENT IN A GRADUATED CYLINDER

Procedure. Pass a quantity of powder sufficient to complete the test through a sieve with apertures greater than or equal to 1.0 mm, if necessary, to break up agglomerates that may have formed during storage; this must be done gently to avoid changing the nature of the material. Into a dry, graduated, 250 mL cylinder (readable to 2 mL), gently introduce, without compacting, approximately 100 g (*m*) of the test sample weighed with 0.1 per cent accuracy. If necessary, carefully level the powder without compacting, and read the unsettled apparent volume (*V*₀) to the nearest graduated unit. Calculate the bulk density in grams per millilitre using the formula *m/V*₀. Generally, replicate determinations are desirable for the determination of this property.

If the powder density is too low or too high, such that the test sample has an untapped apparent volume of more than 250 mL or less than 150 mL, it is not possible to use 100 g of powder sample. In this case, a different amount of powder is selected as the test sample, such that its untapped apparent volume is between 150 mL and 250 mL (apparent volume greater than or equal to 60 per cent of the total volume of the cylinder); the mass of the test sample is specified in the expression of results.

For test samples having an apparent volume between 50 mL and 100 mL, a 100 mL cylinder readable to 1 mL can be used; the volume of the cylinder is specified in the expression of results.

METHOD 2: MEASUREMENT IN A VOLUMETER

Apparatus. The apparatus (Figure 2.9.34.-1) consists of a top funnel fitted with a 1.0 mm sieve, mounted over a baffle box containing 4 glass baffles over which the powder slides and bounces as it passes. At the bottom of the baffle box is a funnel that collects the powder and allows it to pour into a cup mounted directly below it. The cup may be cylindrical (25.00 ± 0.05 mL volume with an internal diameter of 30.00 ± 2.00 mm) or cubical (16.39 ± 0.20 mL volume with internal dimensions of 25.400 ± 0.076 mm).

(20) This chapter has undergone pharmacopoeial harmonisation. See chapter 5.8. *Pharmacopoeial harmonisation*.

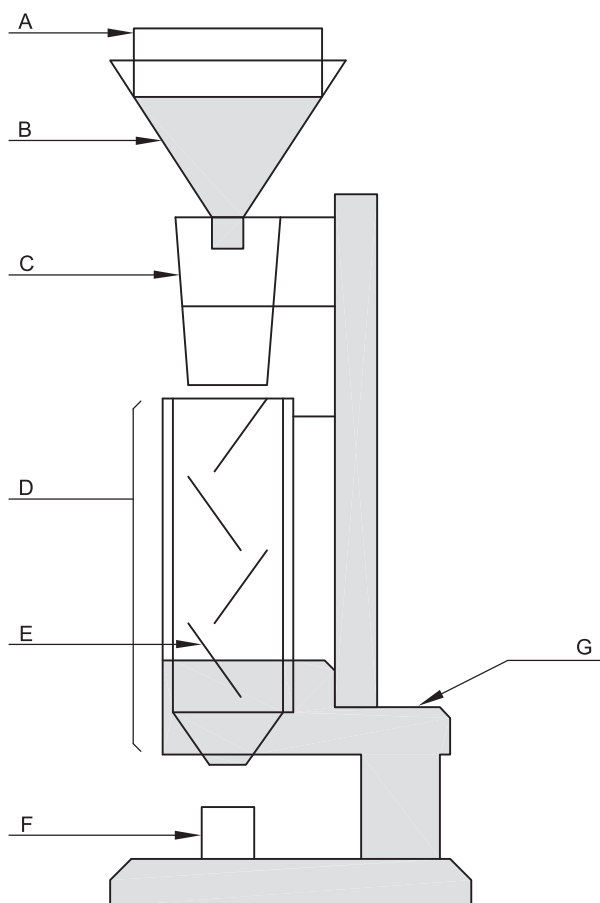

- | | |
|-------------------|-----------------|
| A. 1.0 mm sieve | E. glass baffle |
| B. powder funnel | F. cup |
| C. loading funnel | G. stand |
| D. baffle box | |

Figure 2.9.34.-1. – Volumeter

Procedure. Allow an excess of powder to flow through the apparatus into the sample receiving cup until it overflows, using a minimum of 25 cm³ of powder with the cubical cup and 35 cm³ of powder with the cylindrical cup. Carefully, scrape excess powder from the top of the cup by smoothly moving the edge of the blade of a spatula perpendicular to and in contact with the top surface of the cup, taking care to keep the spatula perpendicular to prevent packing or removal of powder from the cup. Remove any material from the side of the cup and determine the mass (*M*) of the powder to the nearest 0.1 per cent. Calculate the bulk density in grams per millilitre using the formula M/V_0 (where V_0 is the volume of the cup) and record the average of 3 determinations using 3 different powder samples.

METHOD 3: MEASUREMENT IN A VESSEL

Apparatus. The apparatus consists of a 100 mL cylindrical vessel of stainless steel with dimensions as specified in Figure 2.9.34.-2.

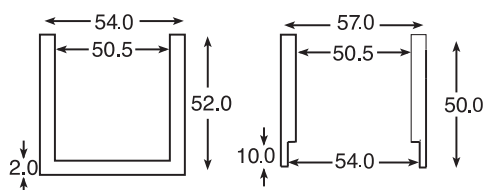
Figure 2.9.34.-2. – Measuring vessel (left) and cap (right)
Dimensions in millimetres

Procedure. Pass a quantity of powder sufficient to complete the test through a 1.0 mm sieve, if necessary, to break up agglomerates that may have formed during storage, and allow the obtained sample to flow freely into the measuring vessel until it overflows. Carefully scrape the excess powder from the top of the vessel as described under Method 2. Determine the mass (M_0) of the powder to the nearest 0.1 per cent by subtracting the previously determined mass of the empty measuring vessel. Calculate the bulk density in grams per millilitre using the formula $M_0/100$ and record the average of 3 determinations using 3 different powder samples.

Tapped density

The tapped density is an increased bulk density attained after mechanically tapping a receptacle containing the powder sample.

The tapped density is obtained by mechanically tapping a graduated measuring cylinder or vessel containing the powder sample. After observing the initial powder volume or mass, the measuring cylinder or vessel is mechanically tapped, and volume or mass readings are taken until little further volume or mass change is observed. The mechanical tapping is achieved by raising the cylinder or vessel and allowing it to drop, under its own mass, a specified distance by one of 3 methods as described below. Devices that rotate the cylinder or vessel during tapping may be preferred to minimise any possible separation of the mass during tapping down.

METHOD 1

Apparatus. The apparatus (Figure 2.9.34.-3) consists of the following:

- a 250 mL graduated cylinder (readable to 2 mL) with a mass of 220 ± 44 g;
- a settling apparatus capable of producing, per minute, either nominally 250 ± 15 taps from a height of 3 ± 0.2 mm, or nominally 300 ± 15 taps from a height of 14 ± 2 mm. The support for the graduated cylinder, with its holder, has a mass of 450 ± 10 g.

Procedure. Proceed as described above for the determination of the bulk volume (V_0). Secure the cylinder in the support. Carry out 10, 500 and 1250 taps on the same powder sample and read the corresponding volumes V_{10} , V_{500} and V_{1250} to the nearest graduated unit. If the difference between V_{500} and V_{1250} is less than or equal to 2 mL, V_{1250} is the tapped volume. If the difference between V_{500} and V_{1250} exceeds 2 mL, repeat in increments of, for example, 1250 taps, until the difference between successive measurements is less than or equal to 2 mL. Fewer taps may be appropriate for some powders, when validated. Calculate the tapped density in grams per millilitre using the formula m/V_f (where V_f is the final tapped volume). Generally, replicate determinations are desirable for the determination of this property. Specify the drop height with the results.

If it is not possible to use a 100 g test sample, use a reduced amount and a suitable 100 mL graduated cylinder (readable to 1 mL) weighing 130 ± 16 g and mounted on a support weighing 240 ± 12 g. If the difference between V_{500} and V_{1250} is less than or equal to 1 mL, V_{1250} is the tapped volume. If the difference between V_{500} and V_{1250} exceeds 1 mL, repeat in increments of, for example, 1250 taps, until the difference between successive measurements is less than or equal to 1 mL. The modified test conditions are specified in the expression of the results.

METHOD 2

Procedure. Proceed as directed under Method 1 except that the mechanical tester provides a fixed drop of 3 ± 0.2 mm at a nominal rate of 250 taps per minute.

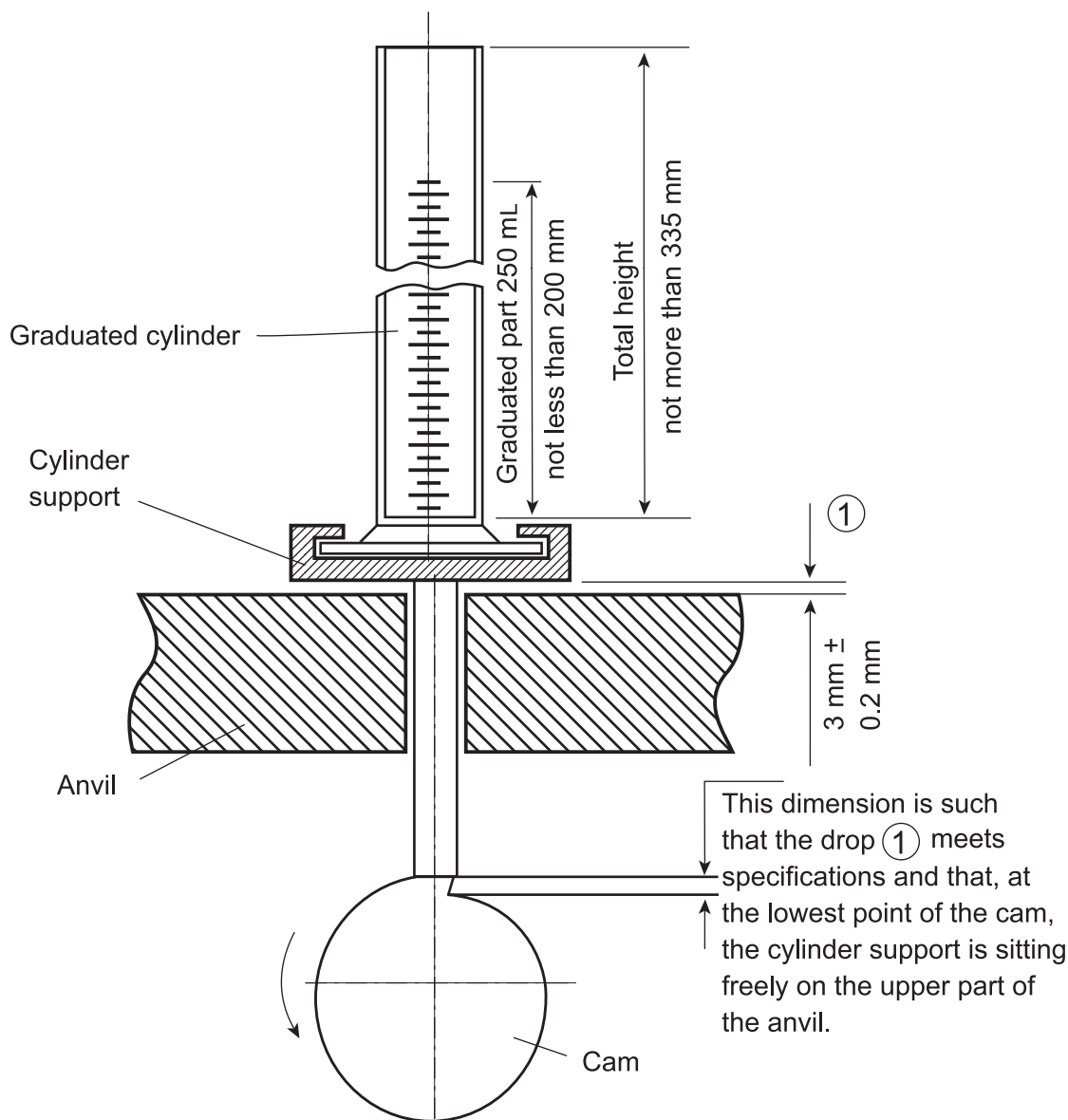

Figure 2.9.34.-3. – Settling device for powder samples
Dimensions in millimetres

METHOD 3

Procedure. Proceed as described under Method 3 for measuring the bulk density, using the measuring vessel equipped with the cap shown in Figure 2.9.34.-2. The measuring vessel with the cap is lifted 50-60 times per minute by the use of a suitable tapped density tester. Carry out 200 taps, remove the cap and carefully scrape excess powder from the top of the measuring vessel as described under Method 3 for measuring the bulk density. Repeat the procedure using 400 taps. If the difference between the 2 masses obtained after 200 and 400 taps exceeds 2 per cent, repeat the test using 200 additional taps until the difference between successive measurements is less than 2 per cent. Calculate the tapped density in grams per millilitre using the formula $M_f/100$ (where M_f is the mass of powder in the measuring vessel). Record the average of 3 determinations using 3 different powder samples. The test conditions, including tapping height, are specified in the expression of the results.

Measures of powder compressibility

Because the interparticulate interactions influencing the bulking properties of a powder are also the interactions that interfere with powder flow, a comparison of the bulk and

tapped densities can give a measure of the relative importance of these interactions in a given powder. Such a comparison is often used as an index of the ability of the powder to flow, for example the compressibility index or the Hausner ratio.

The compressibility index and Hausner ratio are measures of the propensity of a powder to be compressed as described above. As such, they are measures of the powder's ability to settle, and they permit an assessment of the relative importance of interparticulate interactions. In a free-flowing powder, such interactions are less significant, and the bulk and tapped densities will be closer in value. For more-poorly flowing materials, there are frequently greater interparticulate interactions, and a greater difference between the bulk and tapped densities will be observed. These differences are reflected in the compressibility index and the Hausner ratio.

Compressibility index:

$$\frac{100 (V_0 - V_f)}{V_0}$$

V_0 = unsettled apparent volume;

V_f = final tapped volume.

Hausner Ratio:

$$\frac{V_0}{V_f}$$

Depending on the material, the compressibility index can be determined using V_{10} instead of V_0 . If V_{10} is used, it is clearly stated with the results.

04/2019:20935



2.9.35. POWDER FINENESS⁽²¹⁾

Particle-size distribution is estimated by analytical sieving (2.9.38) or by application of other suitable methods where appropriate. A simple descriptive classification of powder fineness is provided in this chapter. For practical reasons, sieves are commonly used to measure powder fineness. Sieving is most suitable where a majority of the particles are larger than about 75 µm, although it can be used for some powders having smaller particle sizes where the method can be validated. Light diffraction is also a widely used technique for measuring the size of a wide range of particles.

Where the cumulative distribution has been determined by analytical sieving or by application of other methods, particle size may be characterised in the following manner:

- x_{90} = particle size corresponding to 90 per cent of the cumulative undersize distribution;
- x_{50} = median particle size (i.e. 50 per cent of the particles are smaller and 50 per cent of the particles are larger);
- x_{10} = particle size corresponding to 10 per cent of the cumulative undersize distribution.

It is recognised that the symbol d is also widely used to designate these values. Therefore, the symbols d_{90} , d_{50} , d_{10} may be used.

The following parameters may be defined based on the cumulative distribution.

$Q_r(x)$ = cumulative distribution of particles with a dimension less than or equal to x where the subscript r reflects the distribution type.

r	Distribution type
0	Number
1	Length
2	Area
3	Volume

Therefore, by definition:

$$Q_r(x) = 0.90 \text{ when } x = x_{90}$$

$$Q_r(x) = 0.50 \text{ when } x = x_{50}$$

$$Q_r(x) = 0.10 \text{ when } x = x_{10}$$

An alternative but less informative method of classifying powder fineness is by use of the descriptive terms in Table 2.9.35.-1.

Table 2.9.35.-1.

Classification of powders by fineness		
Descriptive term	x_{50} (µm)	Cumulative distribution by volume basis, $Q_3(x)$
Coarse	> 355	$Q_3(355) < 0.50$
Moderately fine	180 - 355	$Q_3(180) < 0.50$ and $Q_3(355) \geq 0.50$
Fine	125 - 180	$Q_3(125) < 0.50$ and $Q_3(180) \geq 0.50$
Very fine	≤ 125	$Q_3(125) \geq 0.50$

01/2010:20936



2.9.36. POWDER FLOW⁽²²⁾

The widespread use of powders in the pharmaceutical industry has generated a variety of methods for characterising powder flow. Not surprisingly, scores of references appear in the pharmaceutical literature, attempting to correlate the various measures of powder flow to manufacturing properties. The development of such a variety of test methods was inevitable; powder behavior is multifaceted and thus complicates the effort to characterise powder flow.

The purpose of this chapter is to review the methods for characterising powder flow that have appeared most frequently in the pharmaceutical literature. In addition, while it is clear that no single and simple test method can adequately characterise the flow properties of pharmaceutical powders, this chapter proposes the standardisation of test methods that may be valuable during pharmaceutical development.

4 commonly reported methods for testing powder flow are:

- angle of repose,
- compressibility index or Hausner ratio,
- flow rate through an orifice,
- shear cell.

In addition, numerous variations of each of these basic methods are available. Given the number of test methods and variations, standardising the test methodology, where possible, would be advantageous.

With this goal in mind, the most frequently used methods are discussed below. Important experimental considerations are identified and recommendations are made regarding standardisation of the methods. In general, any method of measuring powder flow must be practical, useful, reproducible and sensitive, and must yield meaningful results. It bears repeating that no simple powder flow method will adequately or completely characterise the wide range of flow properties experienced in the pharmaceutical industry. An appropriate strategy may well be the use of multiple standardised test methods to characterise the various aspects of powder flow as needed by the pharmaceutical scientist.

ANGLE OF REPOSE

The angle of repose has been used in several branches of science to characterise the flow properties of solids. Angle of repose is a characteristic related to interparticulate friction, or resistance to movement between particles. Angle of repose test results are reported to be very dependent upon the method used. Experimental difficulties arise due to segregation of material and consolidation or aeration of the powder as the cone is formed. Despite its difficulties, the method continues

(21) This chapter has undergone pharmacopoeial harmonisation. See chapter 5.8. *Pharmacopoeial harmonisation*.

(22) This chapter has undergone pharmacopoeial harmonisation. See chapter 5.8. *Pharmacopoeial harmonisation*.